



72.5kV Dry Air Insulated Dead Tank Vacuum Circuit Breaker



Japan AE Power Systems Corporation

Landic Shimbashi Building, 8-3, Nishi-shimbashi 3-chome,
Minato-ku, Tokyo, 105-003, Japan

Phone +81-3-5405-8932 Fax +81-3-5405-8915
Web: www.jaeps.com

72.5kV Dry Air Insulated Dead Tank VCB

The Dry Air Insulated Dead Tank VCB was born of superb technology and abundant production experience of Japan AE Power Systems Corporation. It is a circuit breaker employing vacuum interrupters and dry air for insulation. In order to use no SF₆, which is global warming gas, there is no fear to decomposition of gas due to current interruption. It is therefore a highly reliable and high-performance circuit breaker.



No SF₆ GAS

**VACUUM
CIRCUIT
BREAKER**

1 Features

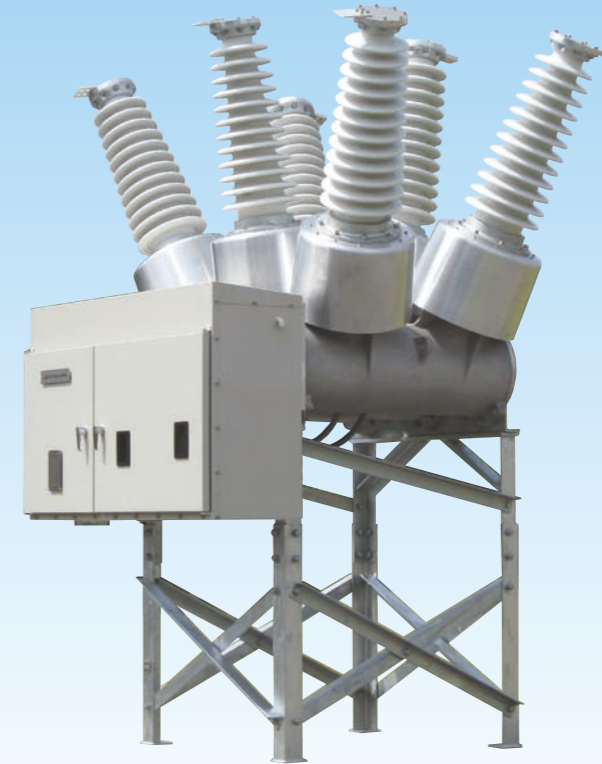

● Contribution to global warming prevention

Dry air insulation are employed instead of SF₆ gas insulation. GWP (Global Warning Potential) of SF₆ is 23,900.

● Excellent breaking performance

Since each current breaking section employs a vacuum interrupter, insulation recovery characteristics are excellent. It exhibits superb characteristics in cases of short-circuit interruption and short line fault interruption.

● Sufficient capability against multiple strokes and evolving faults

Since the vacuum interrupters used are of completely self-arc-diffusion type, this circuit breaker is the only unit that is capable of disposing of multiple strokes and evolving fault currents.

● Reduction of maintenance labor

Use of vacuum interrupters in the current breaking sections eliminates requirements of inspection for these sections. Therefore, man-hours can be saved for maintenance and inspection.

2 Type and Ratings

1 Type and Ratings

Type	NBVOA-60732BB	NBVOA-60740BB
Rated voltage (kV)	72.5	
Withstand voltage	1 min power frequency (kV rms)	140
	1.2x50μs impulse (kV peak)	350
Rated frequency (Hz)	50 / 60	
Rated normal current (A)	2000	
Rated short circuit breaking current (kA)	31.5	40
Rated transient recovery voltage	Rate of rise (kV/μs)	1.47
First pole to clear factor	1.5	
Rated short circuit making current (kA)	80	100
Rated short time current (kA)	31.5 (3s)	40 (3s)
Rated breaking time (cycle)	3	
Rated opening time (s)	0.04	
Make time with no load (s)	0.08	
Operating duty	O-0.3s-CO-15s-CO	
Closing control voltage (Vdc)	48, 100, 110, 125, 250	
Rated tripping voltage (Vdc)	48, 100, 110, 125, 250	
Supply voltage for charging motor	(Vdc)	48, 100, 110, 125, 250
	(Vac)	60, 120, 240
Rated dry-air pressure	72.5 psig (0.5MPa-g) (at 20°C)	
Closing operation system	Spring	
Tripping control system	Spring	
Applicable standard	IEC 62271-100-2003, ANSI C37.06-2000	

2 Installable number of BCT per a bushing

Rated current	MR / SR	Accuracy class	Number of BCT	
2000:5	MR	C800	3	
		C400	3	
		C200	3	
1200:5	SR	C200	3	
		MR	C800	3
			C400	3
600:5	SR	C200	3	
		C800	1	
	MR	C400	3	
		C200	3	
		C200	3	

Notes a) MR : Multi Ratio, SR : Single Ratio
 b) RF= 2.0
 c) Please contact us for BCT as per IEC standard.

3 Construction

1 Overall construction

For each phase, a current breaking vacuum interrupter is accommodated in the grounded tank. The operation system is such that closing and tripping are effected by spring force.

The operating mechanism and 3-phase interlinkage are assembled on a common base, which is installed on the frame legs.

2 Internal construction

The overall structure is composed mainly of grounded tank, vacuum interrupters (VI), insulating rods, bushings and main circuit terminals. Each grounded tank is filled with dry air maintained at a rated pressure of 72.5 psig (0.5MPa-g) (20°C).

Internal construction of vacuum circuit breaker

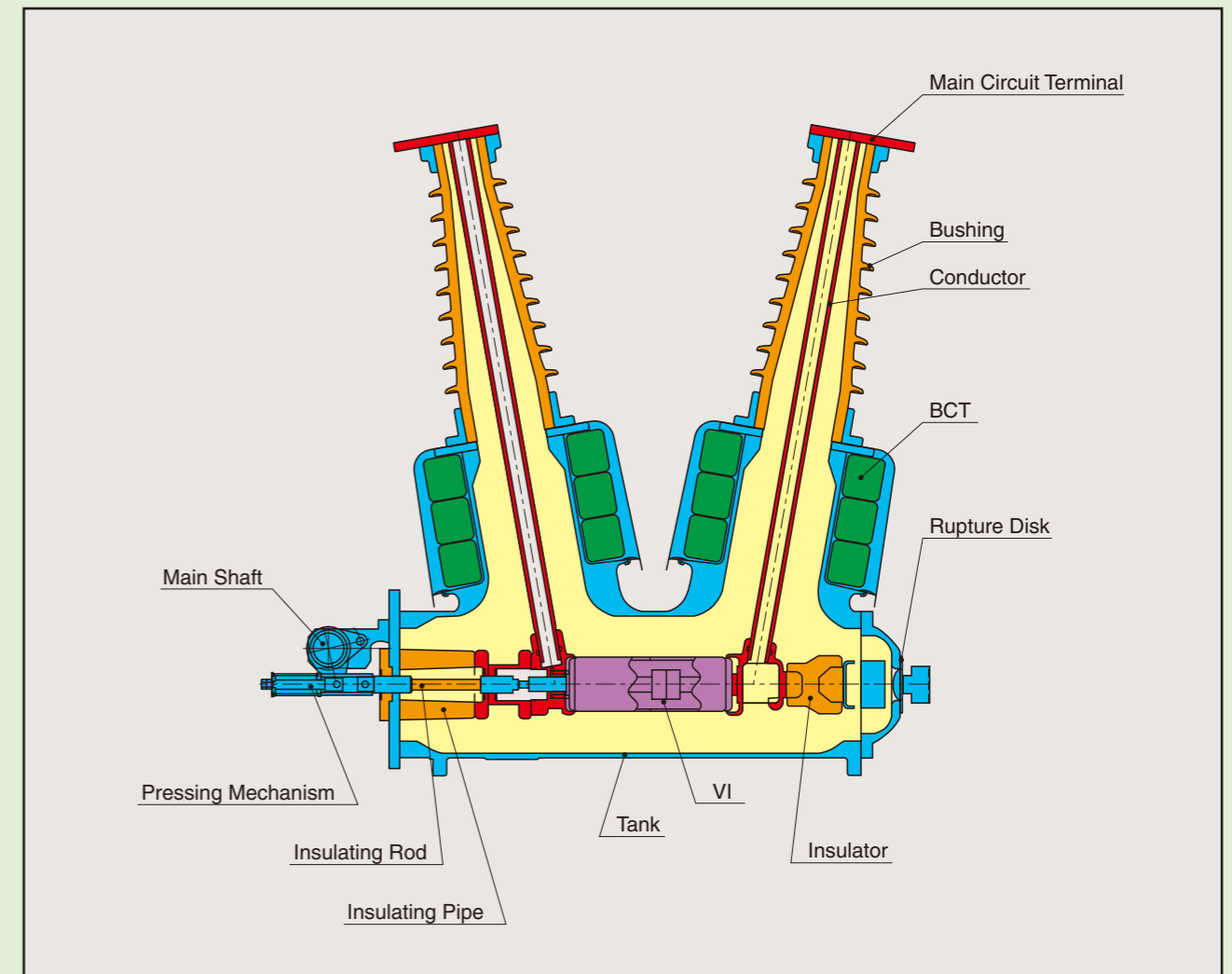

3 Dry air system

Dry air is used for insulation and sealed at the rated pressure of 72.5 psig (0.5MPa-g). The internal pressure is supervised with a density monitor.

When the dry air pressure lowers to 58.0 psig (0.4MPa-g) (20°C), the alarm contact of pressure switch is actuated.

Dry air system

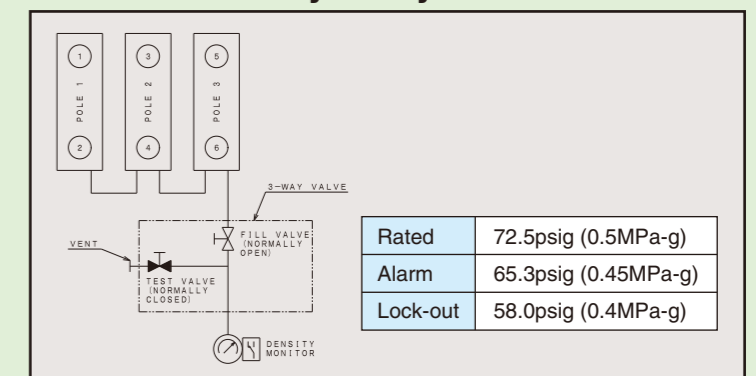

4 External Dimensions

Outline drawing

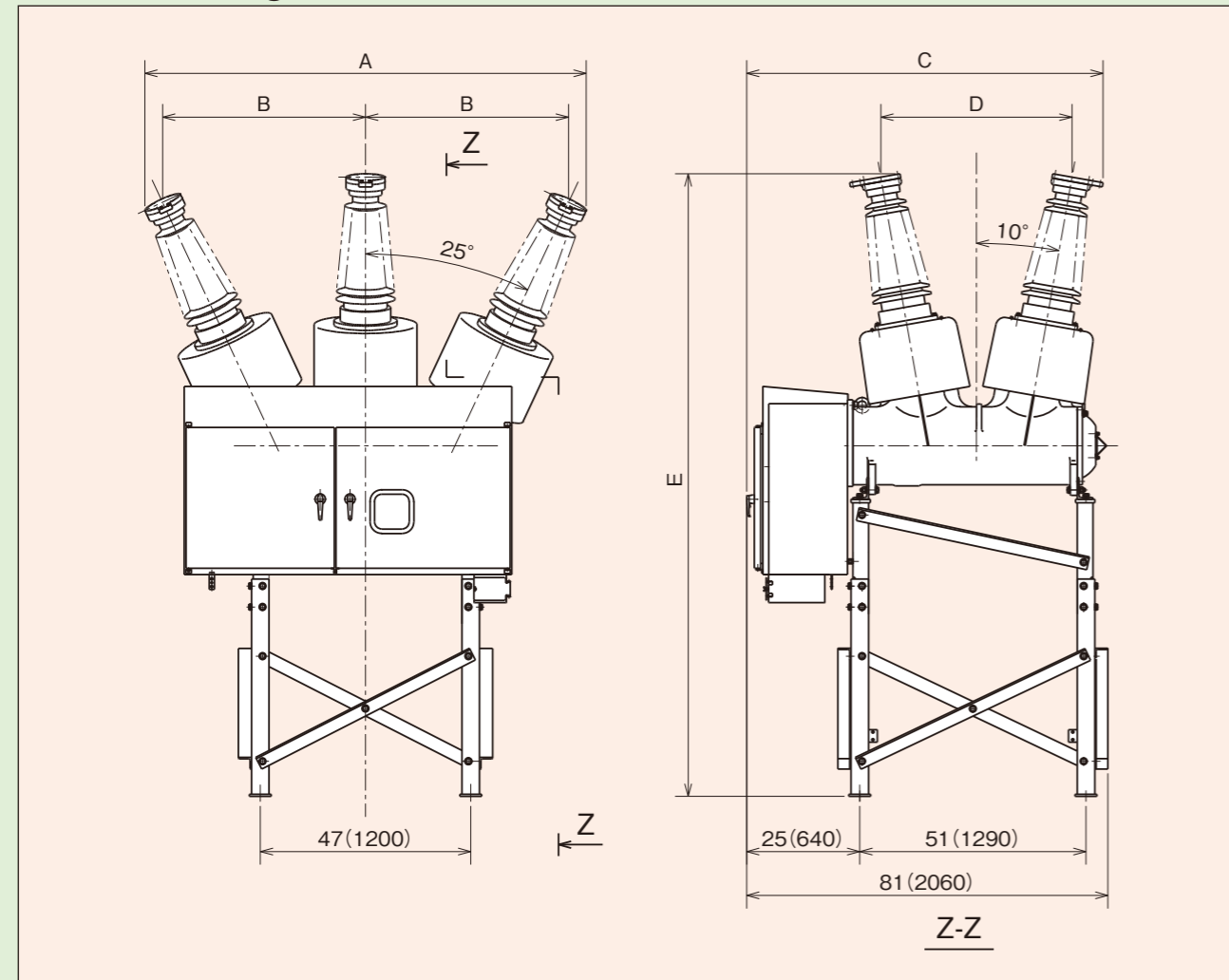

Dimensions

Unit : inch (mm)

Pollution level	A	B	C	D	E	Mass w/o BCT lbs (kg)
Light / Medium	99 (2520)	46 (1160)	80 (2030)	43 (1090)	140 (3550)	4200 (1900)
Heavy / Very heavy	113 (2870)	52 (1330)	83 (2100)	49 (1240)	156 (3970)	4400 (2000)

5 Connections

Standard connection diagram

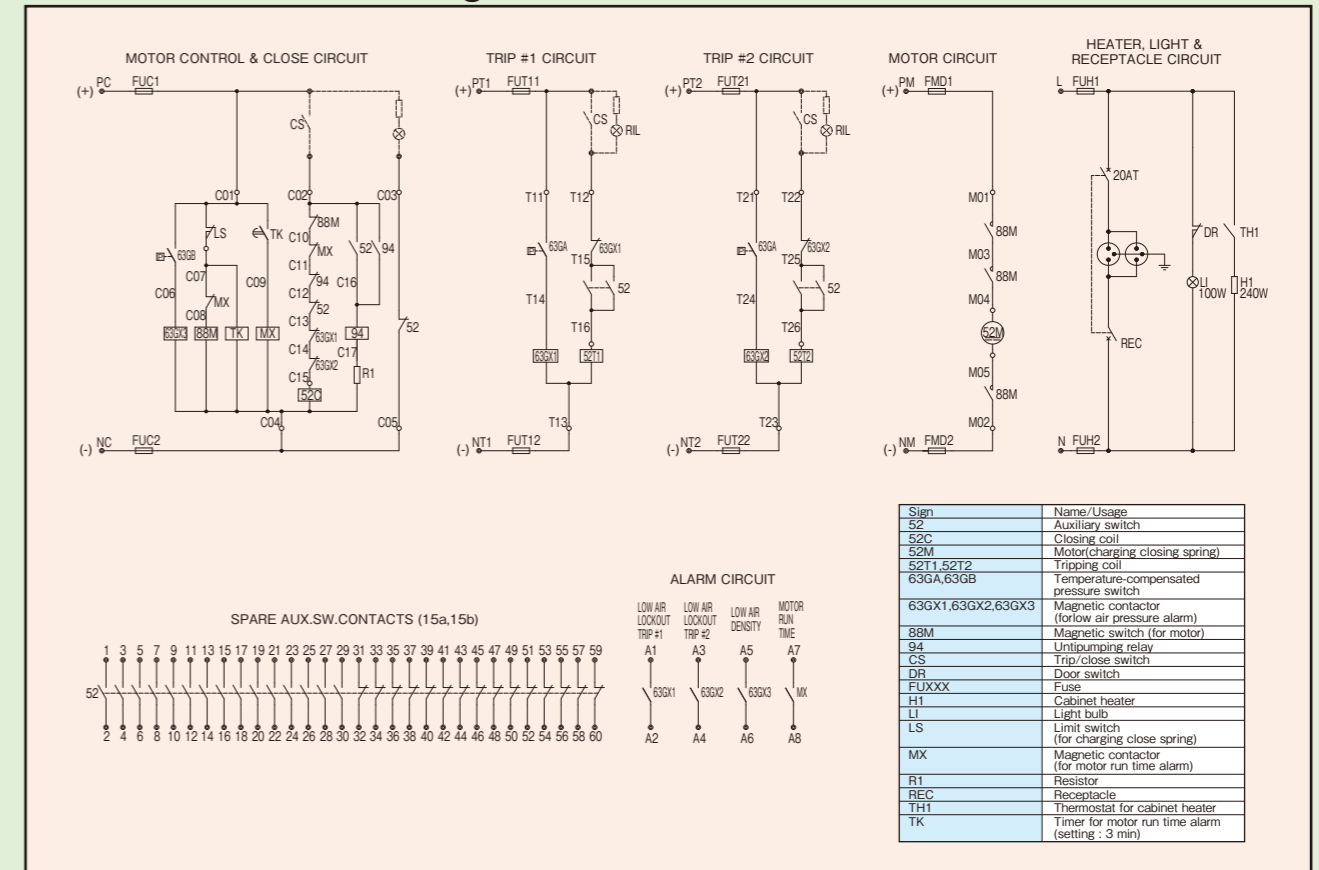

6 Performance

Performance of the circuit breaker has been designed in accordance with ANSI and IEC standard, and verified by type test. All products are shipped after confirmation of various performances by acceptance test based on these standards.

1 Withstand voltage characteristics

Performance of withstand voltage is assured at the specified dry-air pressure. Even though the dry air pressure has been lowered to the alarming level, the required insulation level can be assured. In addition, even though this pressure lowers to the atmospheric pressure, the circuit breaker withstands the rated voltage.

2 Current passing performance

Since the main contacts are located under vacuum, their surfaces are never oxidized and current passing performance is therefore stabilized. In the closing mode of circuit breaker, a pressing force is exerted between main contacts by the effect of pressing spring and sufficient tolerance is assured against closing current and short-time current.

3 Interruption performance

Current breaking is accomplished by a vacuum interrupter with superb insulation recovery performance. Therefore, excellent current breaking performance is demonstrated against short-circuit current (BTF) and even against short line fault current (SLF) and out of phase interruption. In addition, the vacuum interrupter is of completely self-arc-diffusion type and it will assure exact current breaking in half a cycle even in case of multiple-stroke and evolving fault.

Performance of the vacuum circuit breaker has been verified in accordance with ANSI and IEC. Its reliability has been confirmed through sufficient practical performance testing such as mechanical life test, long-term charging test, temperature test, etc.

4 Mechanical life

Due to adoption of simplified operating mechanism, switching characteristics are extremely stabilized. Frequent switching performance has also been verified through continuous mechanical switching test by repeating switching operations more than 10,000 times.

5 Electrical life

Since current breaking is performed in the vacuum interrupter, arcing energy generated during current interruption is extremely low and contact erosion is minimal. This implies long contact life.
Load current switching : 10,000 times
Rated breaking current switching : 20 times